

INSTALLATION INSTRUCTIONS

Can-Am Outlander High Clearance Forward A-Arms

Item	Description	Qty
G	Right Upper A-Arm	1
H	Right Lower A-Arm	1
J	Left Upper A-Arm	1
K	Left Lower A-Arm	1

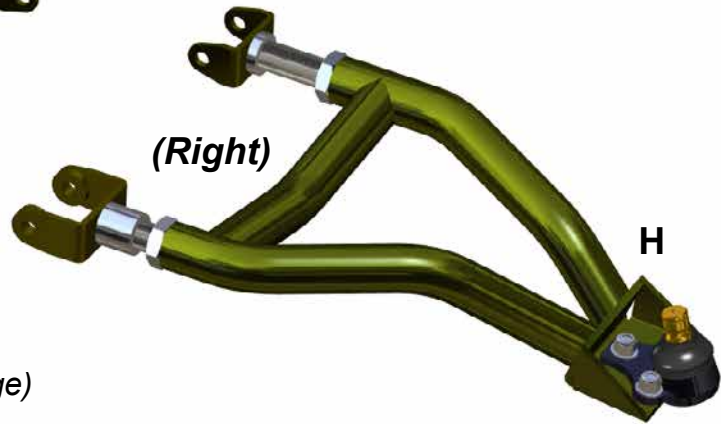
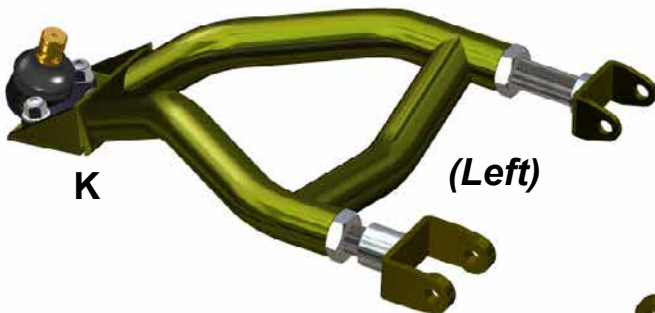
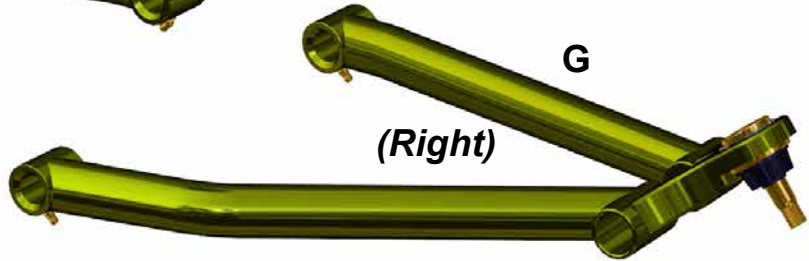
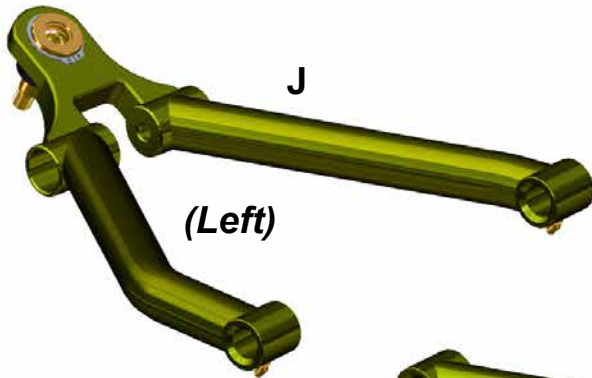

(Kit contents continue on following page)

Read instructions and view illustrations before beginning.

Need help with your installation?



sales@superatv.com



www.superatv.com



1-812-574-7777



8:00am - 9:00pm EST M-Th
8:00am - 7:00pm EST Friday
9:00am - 2:00pm EST Saturday

*Thank You
For Choosing*

SUPERATV.COM

Liability Statement

SuperATV's products are designed to best fit users ATV/UTV under stock conditions. Adding, modifying, or fabricating any factory, or aftermarket, parts will void any warranty provided by SuperATV and is not recommended. SuperATV's products could interfere with other aftermarket accessories. If user has aftermarket products on machine, contact SuperATV to verify that they will work together.

Although SuperATV has thousands of satisfied customers, user should be aware that installing lift kits, long travel, or suspension kits, tires, etc will change the ride of machine and may increase maintenance and part wear. Operating any off-road machine while, or after, consuming alcohol and/or drugs increases risk of bodily harm or death. No warranty or representation is made as to this product's ability to protect user from severe injury or death. SuperATV urges operators and occupants to wear a helmet and appropriate riding gear at all times.

By purchasing and installing SuperATV products, user agrees that should damages occur, SuperATV will not be held responsible for loss of time, use, labor fees, replacement parts, or freight charges. SuperATV, nor any 3rd party, will not be held responsible for any direct, indirect, incidental, special, or consequential damages that result from any product purchased from SuperATV. The total liability of seller to user for all damages, losses, and causes of action, if any, shall not exceed the total purchase price paid for the product that gave rise to the claim.

SuperATV will warranty only parts provided by SuperATV. Any damage or problems with OEM housings, bearings, seals, or other manufacturers products will not be covered by SuperATV. SuperATV parts and products are not warranted if item was not installed properly, misused, or modified.

(Kit contents continued)

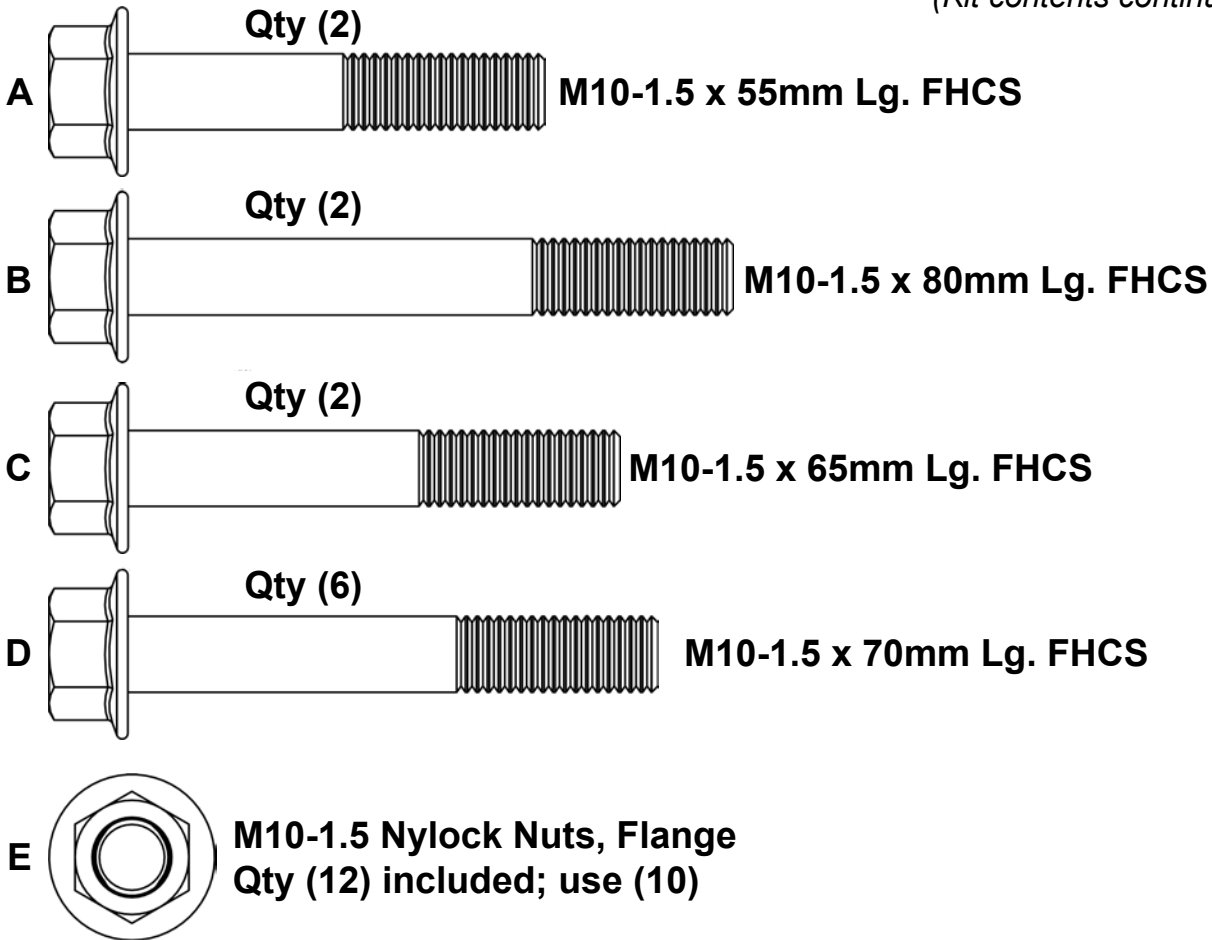

Removal: Keep stock hardware and components.

1. Raise front of machine off ground, secure with jack stands, remove Wheels, and Shocks from A-Arms.
2. Disconnect A-Arms from Knuckles.
3. Remove A-Arms from Frame.
4. Remove stock Bushings and Sleeves from Upper A-Arms.

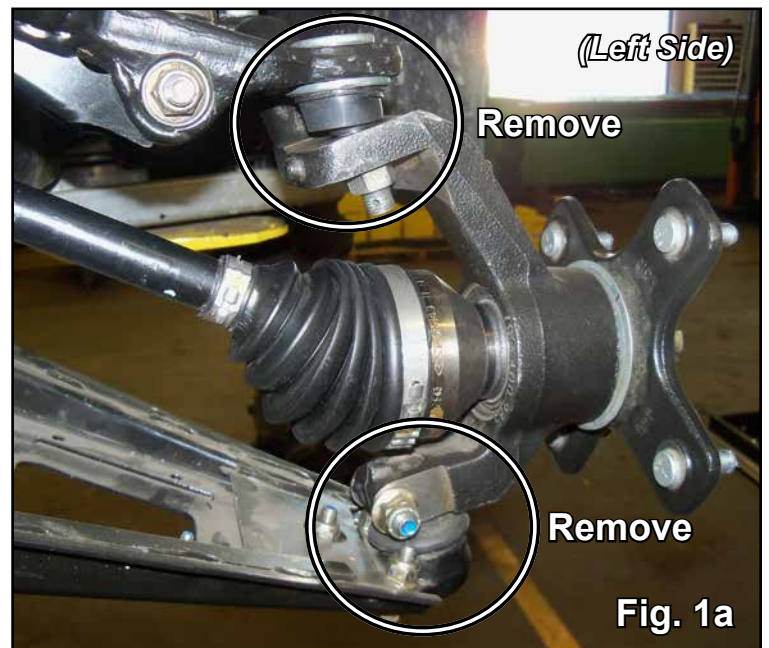
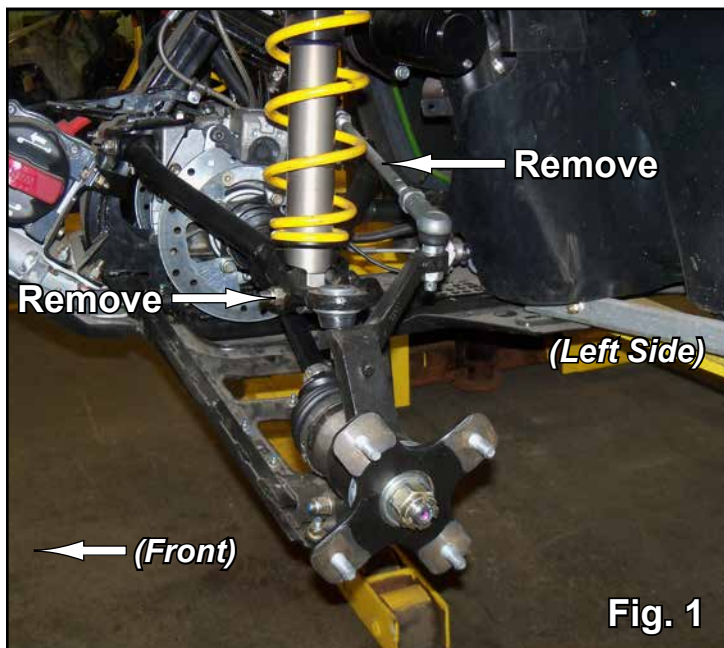

Installation: Do not tighten hardware completely unless noted.

1. Install Lower A-Arms (H)(K) to Frame; Rear most connections use M10-1.5 x 80mm Lg. FHCS (B) and M10-1.5 Nylock Nuts, Flange (E). Forward most connections use M10-1.5 x 70mm Lg. FHCS (D) and M10-1.5 Nylock Nuts, Flange (E). See Figs. 2 - 2b.
2. Reinstall stock Bushings and Sleeves, or SuperATV p/n AAB-CA-001, to Upper A-Arms (G)(J).
 - Install to Frame with M10-1.5 x 70mm Lg. FHCS (D) and M10-1.5 Nylock Nuts (E). See Fig. 3.Install optional Steering Stop at this time. See Page 5.
3. Reinstall Shocks to Upper A-Arms (G)(J) with M10-1.5 x 65mm Lg. FHCS (C) and M10-1.5 Nylock Nuts, Flange (E). See Fig. 4.
4. Install A-Arms (G-K) to Knuckle with stock hardware. See Fig. 5.
5. Tighten all hardware completely.

SuperATV recommends using Loc-Tite on Nuts when installing A-Arms to Frame.

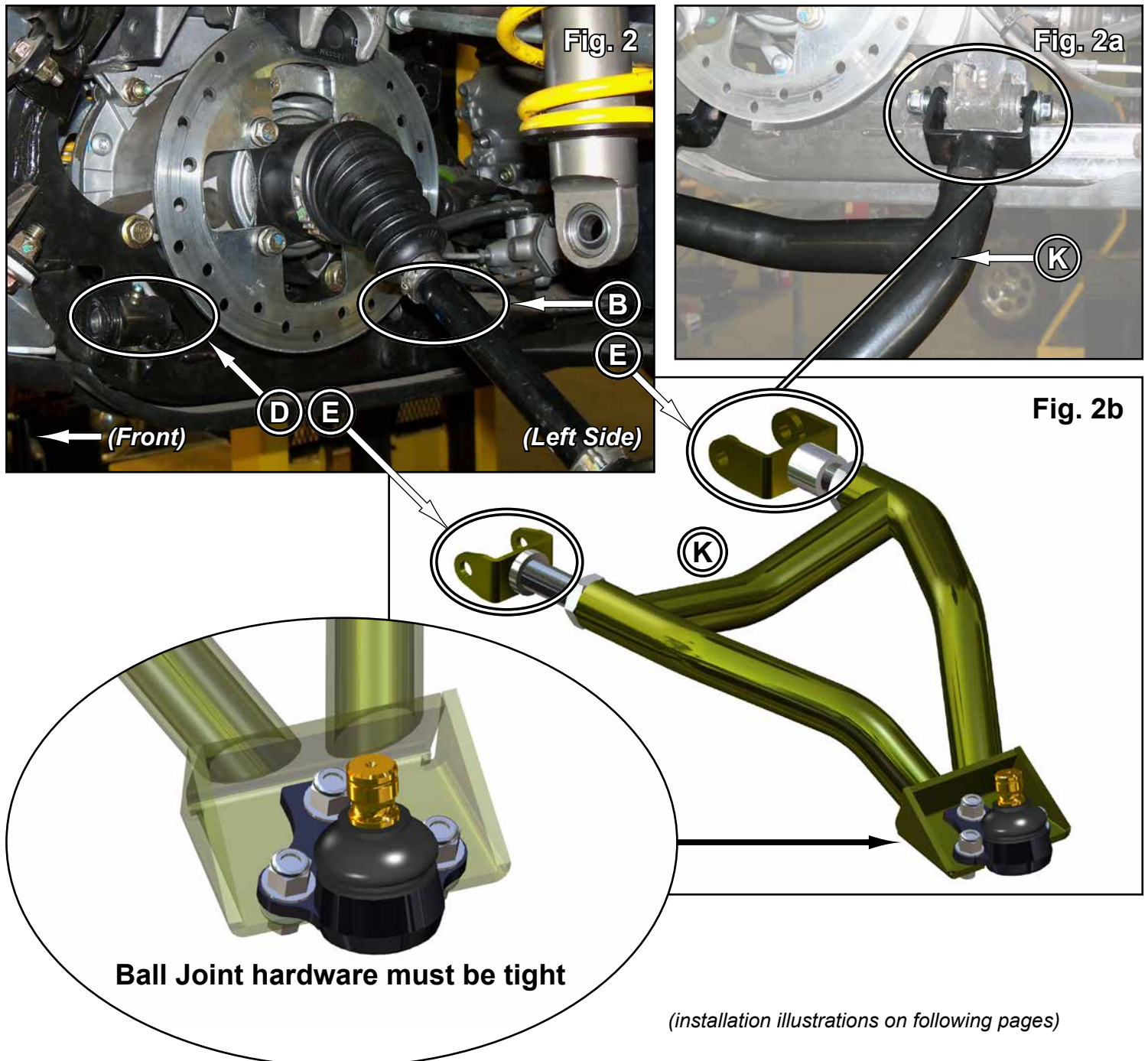

(installation illustrations continued)

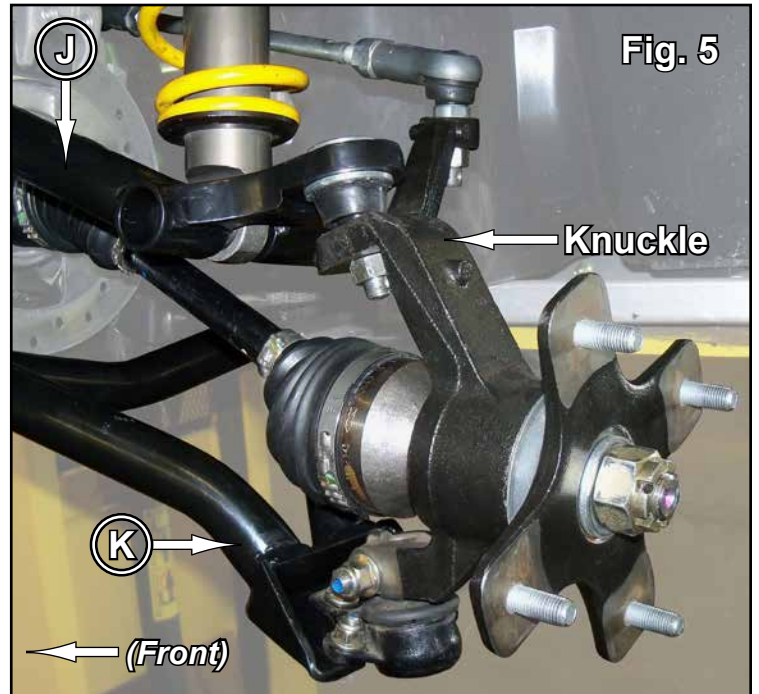
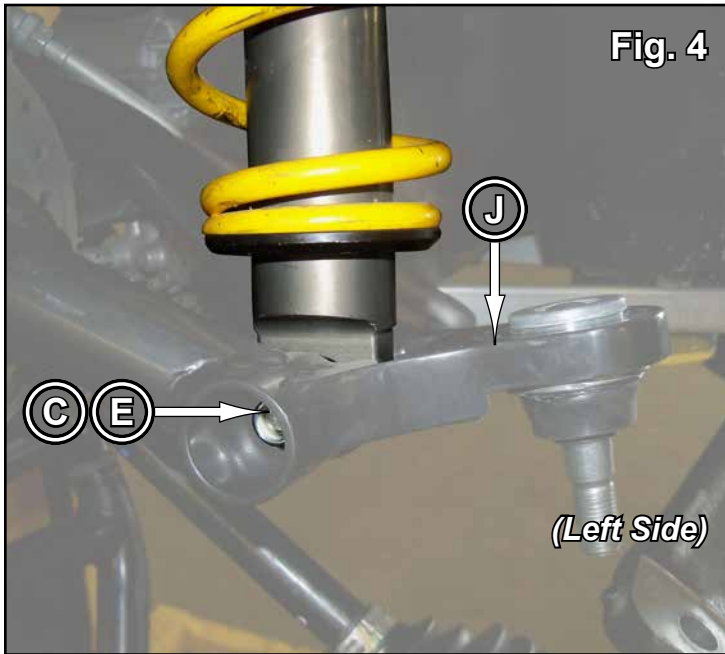
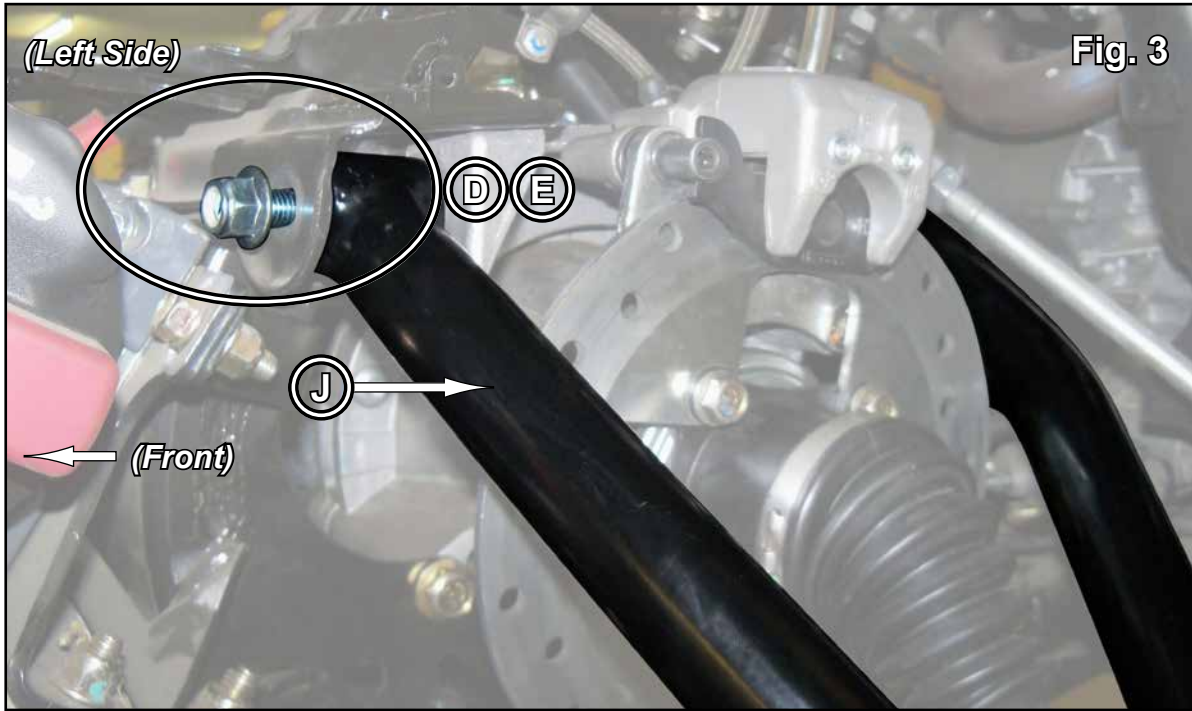

(installation illustrations continue on following pages)

(installation illustrations continued)

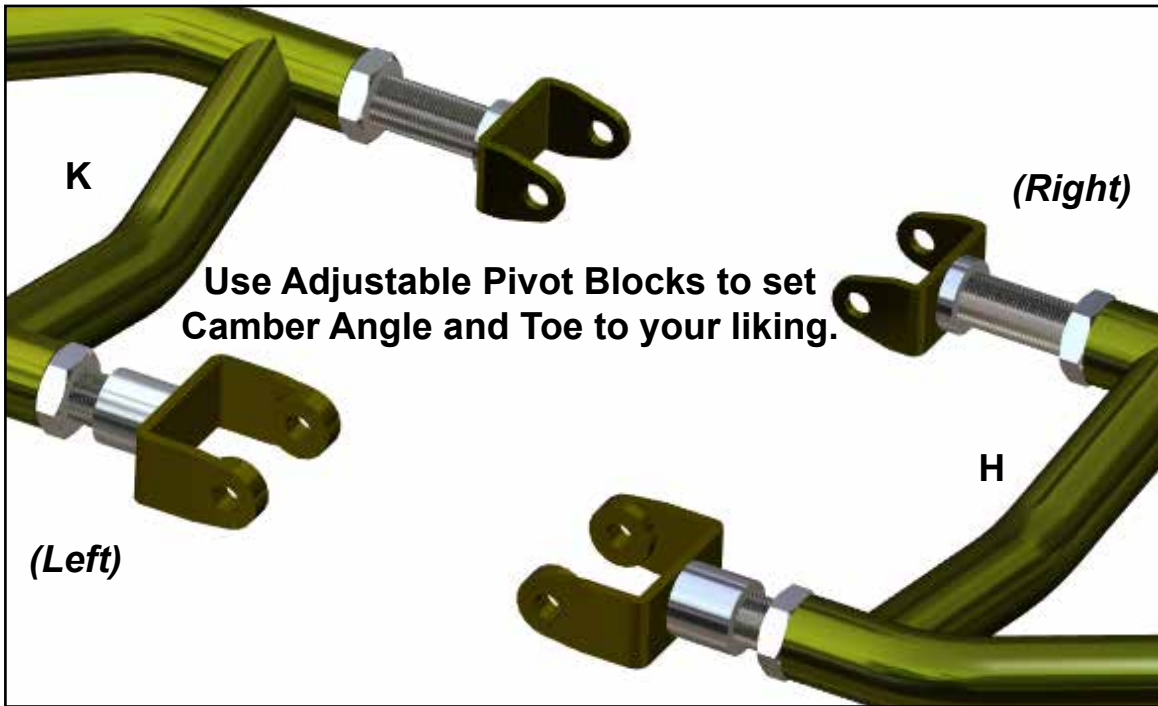

Optional Steering Stop Installation

Remove Tie Rods from Tie Rod Plate and install Tie Rods and Steering Stop to Tie Rod Plate with stock hardware.

