

INSTALLATION INSTRUCTIONS

Flip Windshield for Yamaha Viking

Item	Description
A	Upper Windshield
B	Lower Windshield

- When assembling, do not tighten hardware completely.
- SuperATV has found that installing components to windshields on a workbench, as shown in illustrations, makes for easiest installation.



A

Gasket

Load Seal



B

(kit contents continue on following pages)

Read instructions and view illustrations before beginning.

Need help with your installation?



sales@superatv.com



www.superatv.com



1-812-574-7777



8:00am - 9:00pm EST M-Th
8:00am - 7:00pm EST Friday
9:00am - 2:00pm EST Saturday

*Thank You
For Choosing*

Liability Statement

SuperATV's[®] products are designed to best fit user's ATV/UTV under stock conditions. Adding, modifying, or fabricating any factory or aftermarket parts will void any warranty provided by SuperATV[®] and is not recommended. SuperATV's[®] products could interfere with other aftermarket accessories. If user has aftermarket products on machine, contact SuperATV[®] to verify that they will work together.

Although SuperATV[®] has thousands of satisfied customers, user should be aware that installing lift kits, long travel, or suspension kits, tires, etc. will change the ride of machine and may increase maintenance and part wear. Operating any off-road machine while, or after, consuming alcohol and/or drugs increases risk of bodily harm or death. No warranty or representation is made as to this product's ability to protect user from severe injury or death. SuperATV[®] urges operators and occupants to wear a helmet and appropriate riding gear at all times.

By purchasing and installing SuperATV[®] products, user agrees that should damages occur, SuperATV[®] will not be held responsible for loss of time, use, labor fees, replacement parts, or freight charges. SuperATV[®], nor any 3rd party, will not be held responsible for any direct, indirect, incidental, special, or consequential damages that result from any product purchased from SuperATV[®]. The total liability of seller to user for all damages, losses, and causes of action, if any, shall not exceed the total purchase price paid for the product that gave rise to the claim.

SuperATV[®] will warranty only parts provided by SuperATV[®]. Any damage or problems with OEM housings, bearings, seals, or other manufacturers' products will not be covered by SuperATV[®]. SuperATV[®] parts and products are not warranted if item was not installed properly, misused, or modified.

(kit contents continued)

Item	Description	Qty	Item	Description	Qty
C	Gas Strut	2	G	Right Support	1
D	Latch Assembly	1	H	Left Support	1
E	Pivot Block	4	J	Latch Support	1
F	Clamp	6	K	Support	2

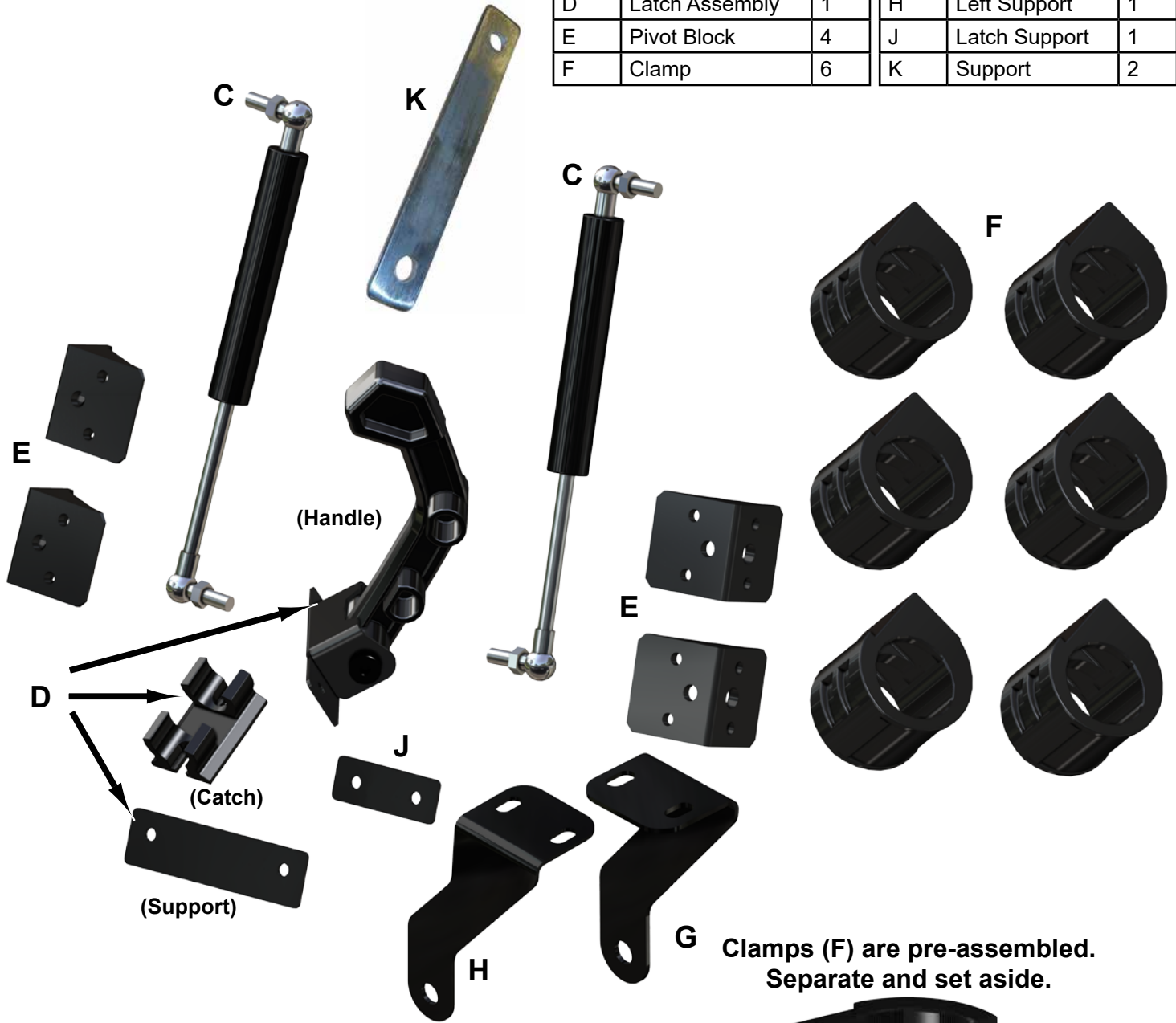

G Clamps (F) are pre-assembled. Separate and set aside.



(kit contents continued)

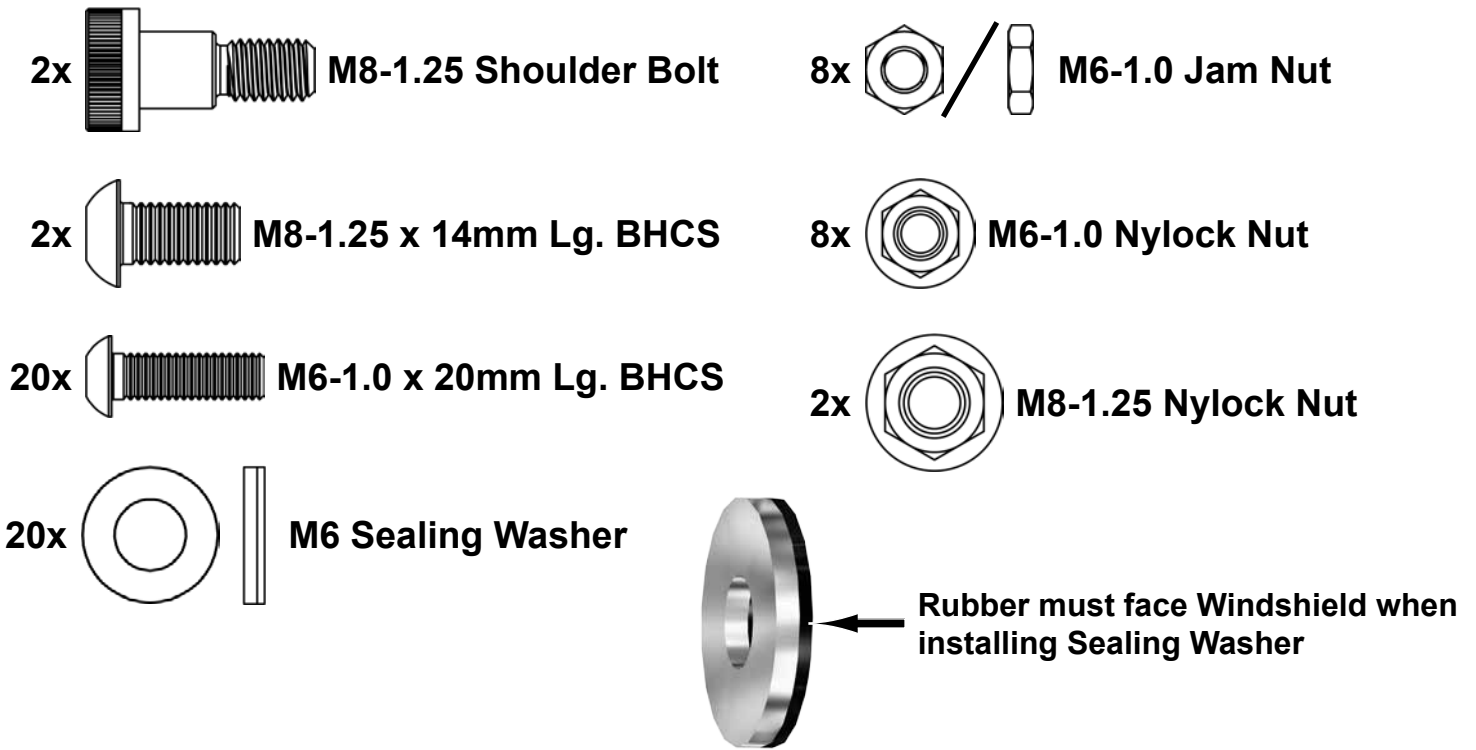

disregard any remaining hardware



Windshield Cleaning:

- Do not use a dry cloth, or your hands, to wipe off Windshield; Scratching will occur.
 - Do not use window cleaning fluids (Windex, 409, etc) or any solvents (gasoline, denatured alcohol, acetone, etc).
 - Never use abrasive cleaners, abrasive pads, or gritty cloths.
1. Thoroughly rinse Windshield to float off dirt and mud.
 2. Using a soft cloth, or microfiber cloth, clean Windshield with warm water and a gentle detergent. Baby shampoo or hand washing soap are recommended.
 3. To prevent water spots, use a chamois and blot Windshield dry.

Reference only; do not assemble at this time.

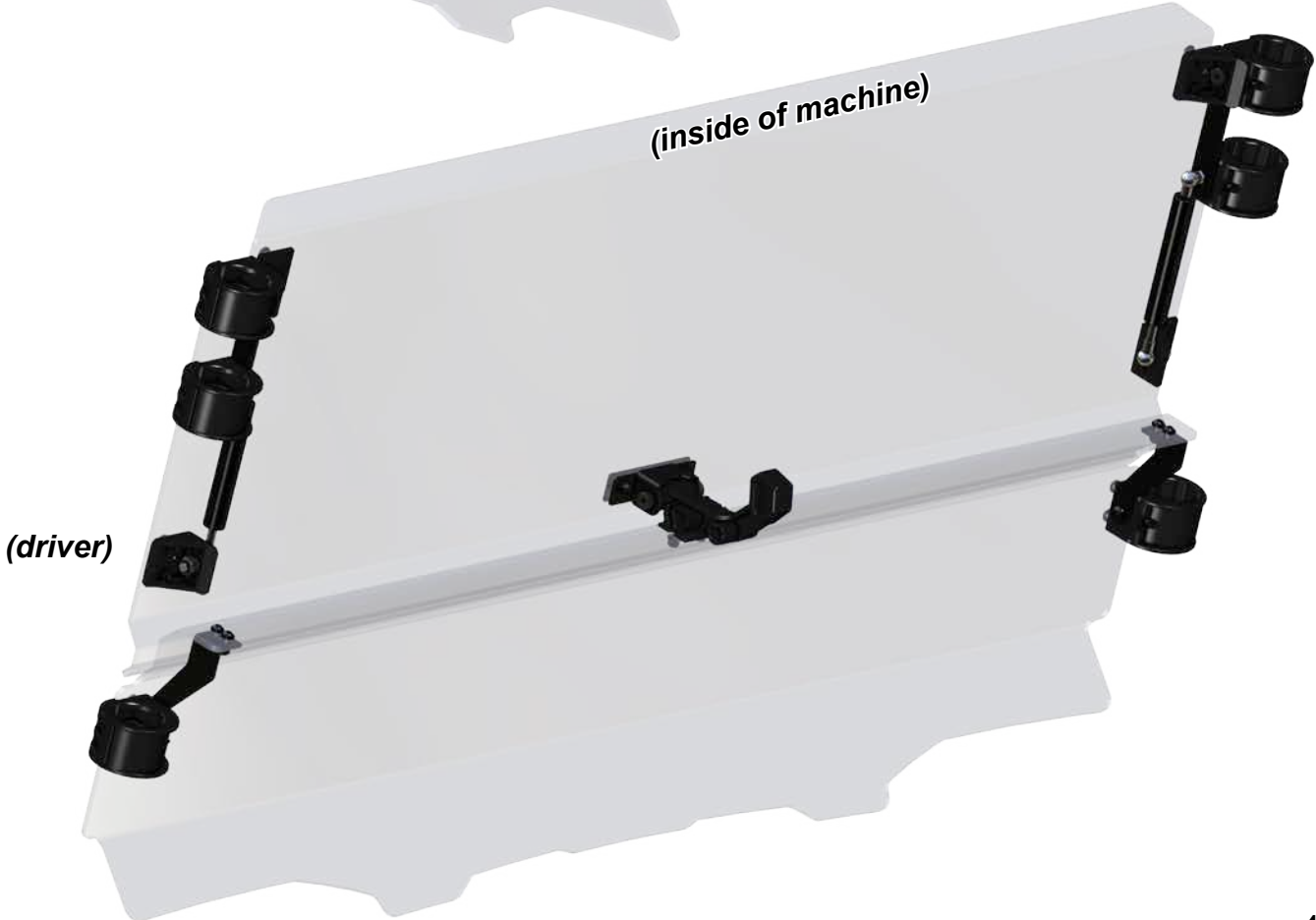
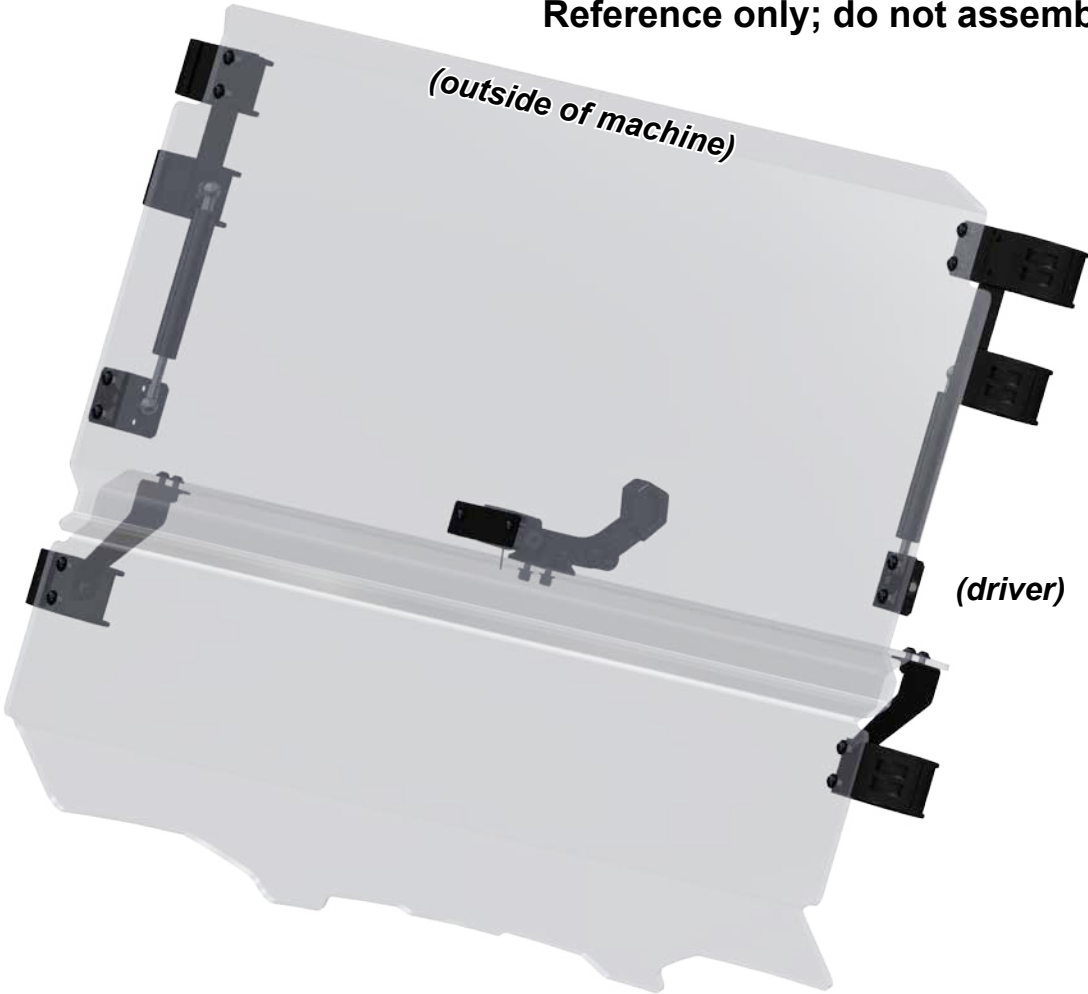

When assembling and installing, do not tighten hardware completely unless noted.

Lower Windshield (B)

- Install Clamp (F) to Lower Windshield (B) with hardware shown.
- Install provided Hood Seal and Gasket to Lower Windshield (B).
- Repeat for opposite side.

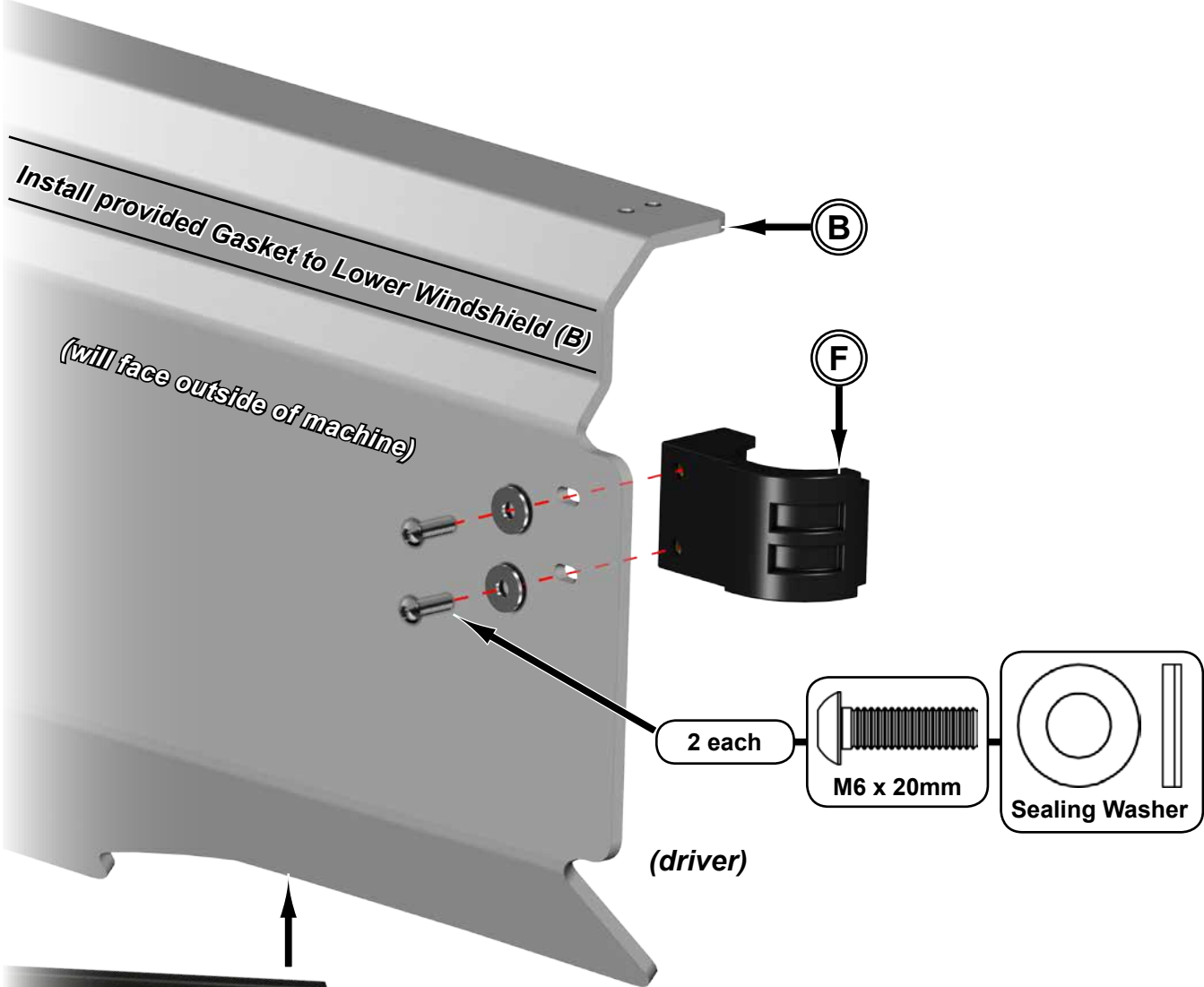

Install Hood Seal along bottom edge of Lower Windshield (B).
To ease installation, soak Seal in hot water before cutting or installing to increase flexibility.

- Install Right/Left Supports (G)(H) to Lower Windshield (B) with hardware shown.
- Secure Right/Left Supports (G)(H) to Clamps (F) with hardware shown.
- Install Catch, part of Latch Assembly (D), to Lower Windshield (B); place Latch Support (J) on bottom section of Lower Windshield (B) and secure with hardware shown.

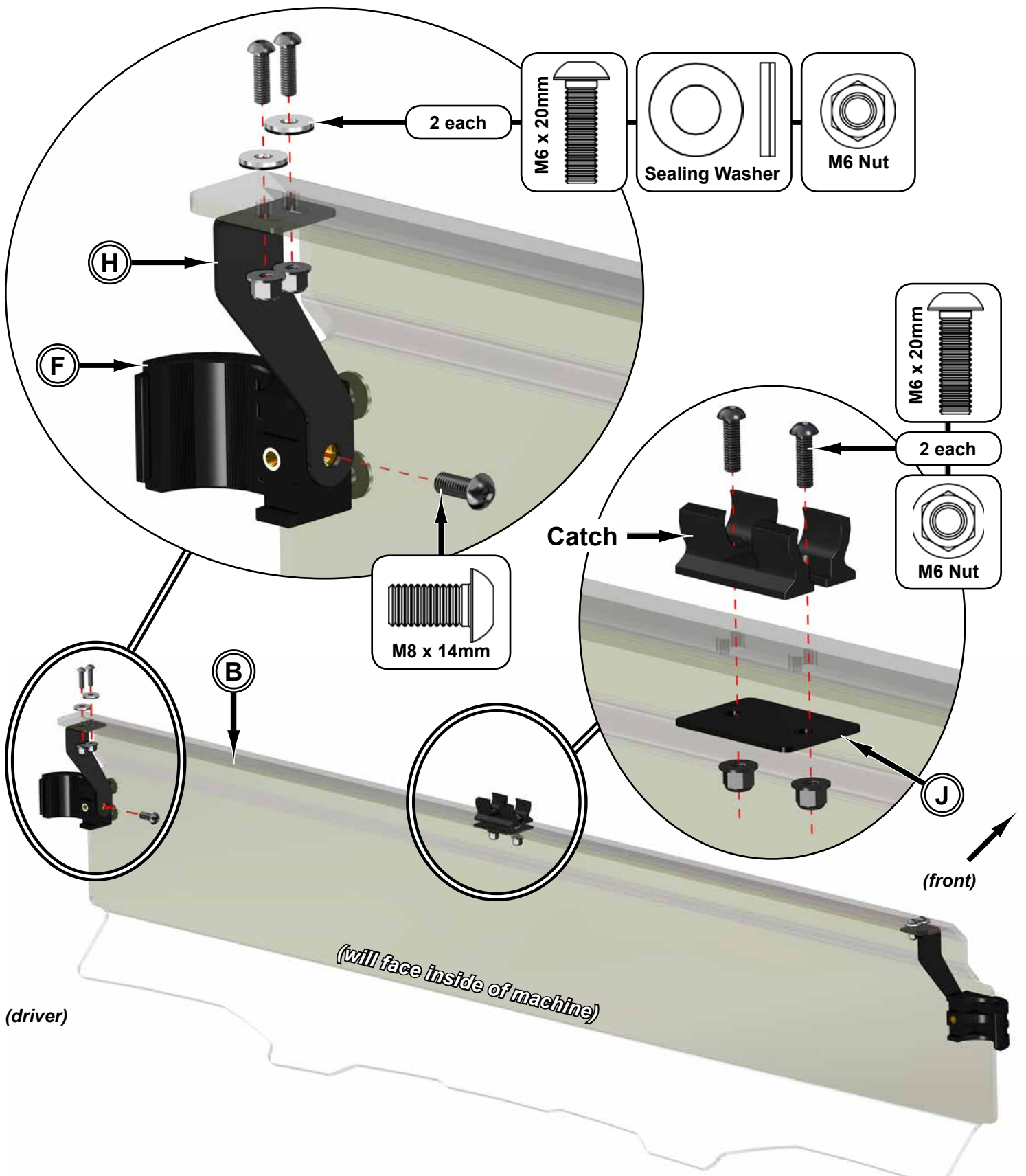

- Install Lower Windshield (B) to Roll Cage with bolts included with Clamps (F).

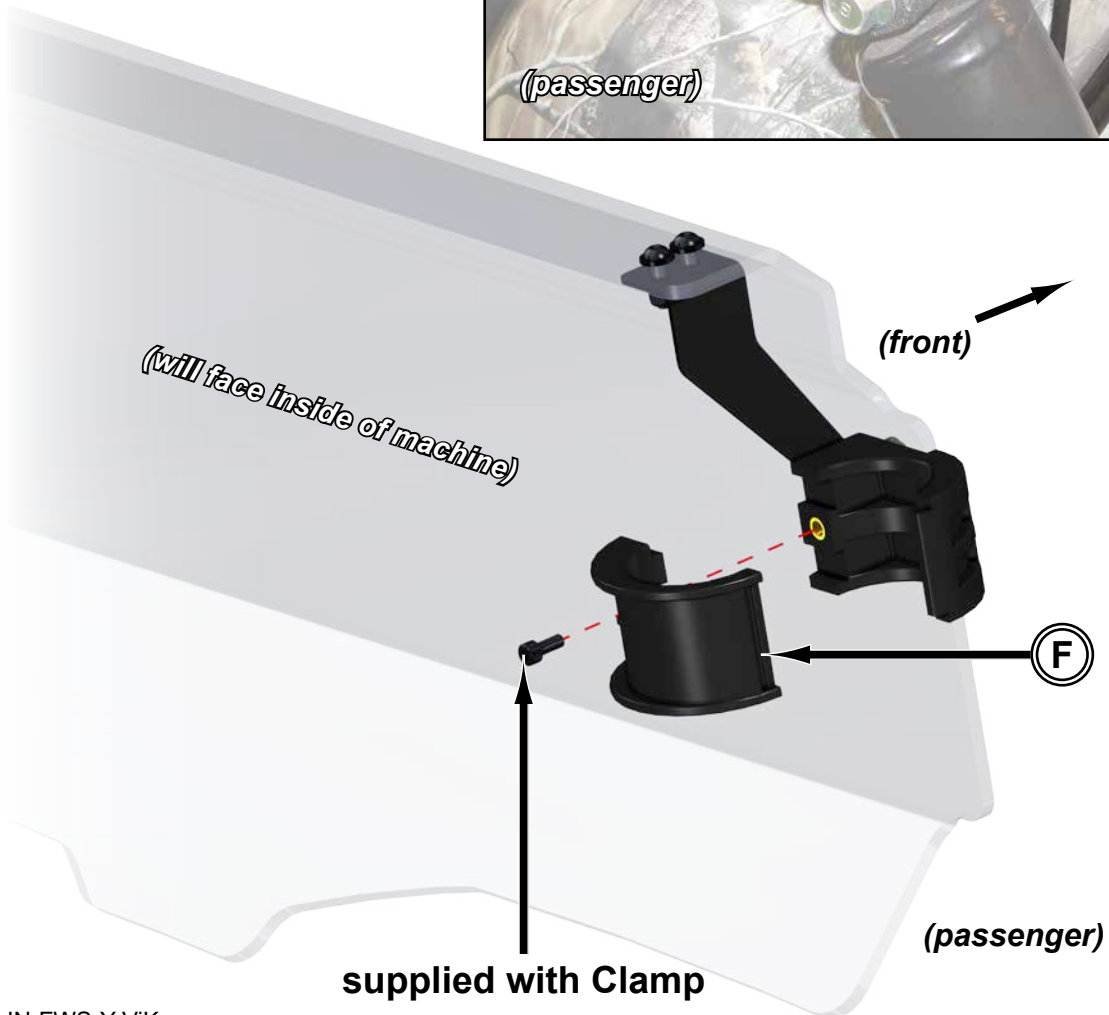
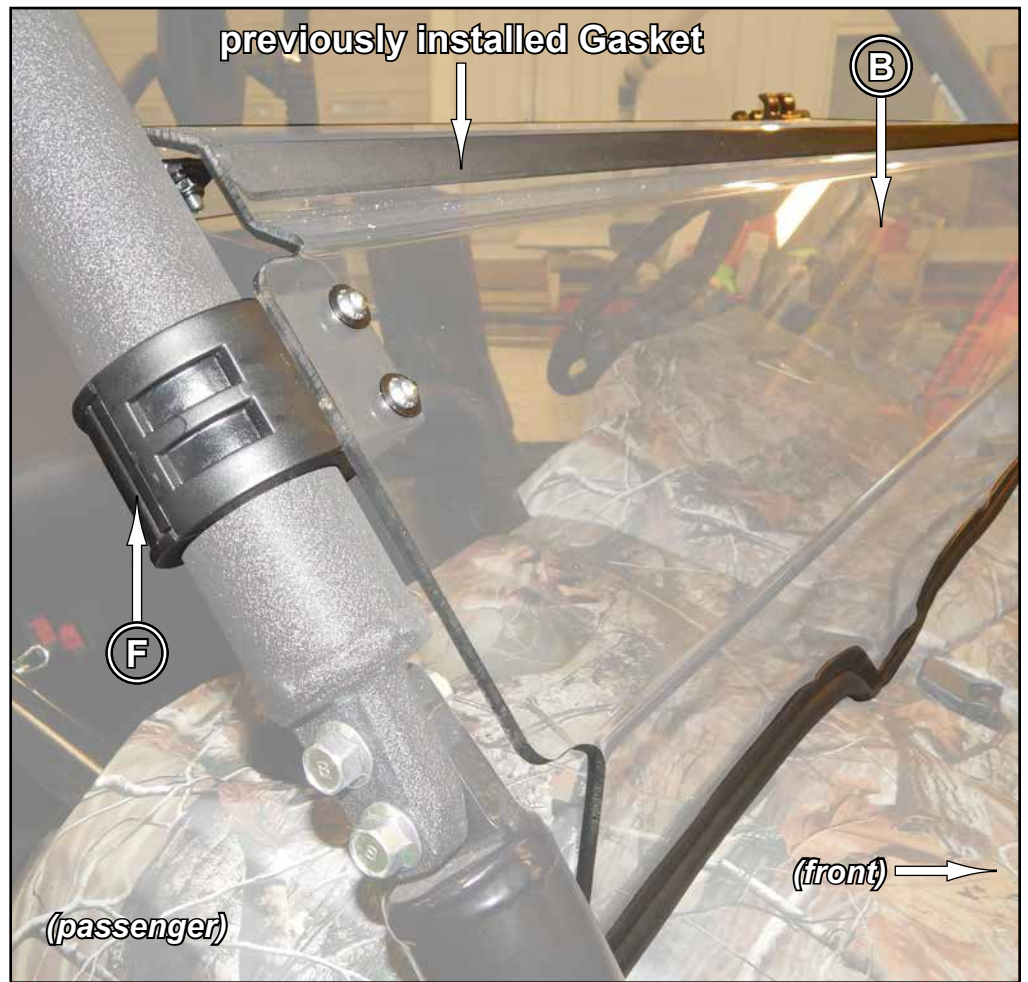

Upper Windshield (A)

- Install Handle and Support, part of Latch Assembly (D), to Upper Windshield (A) with hardware shown.

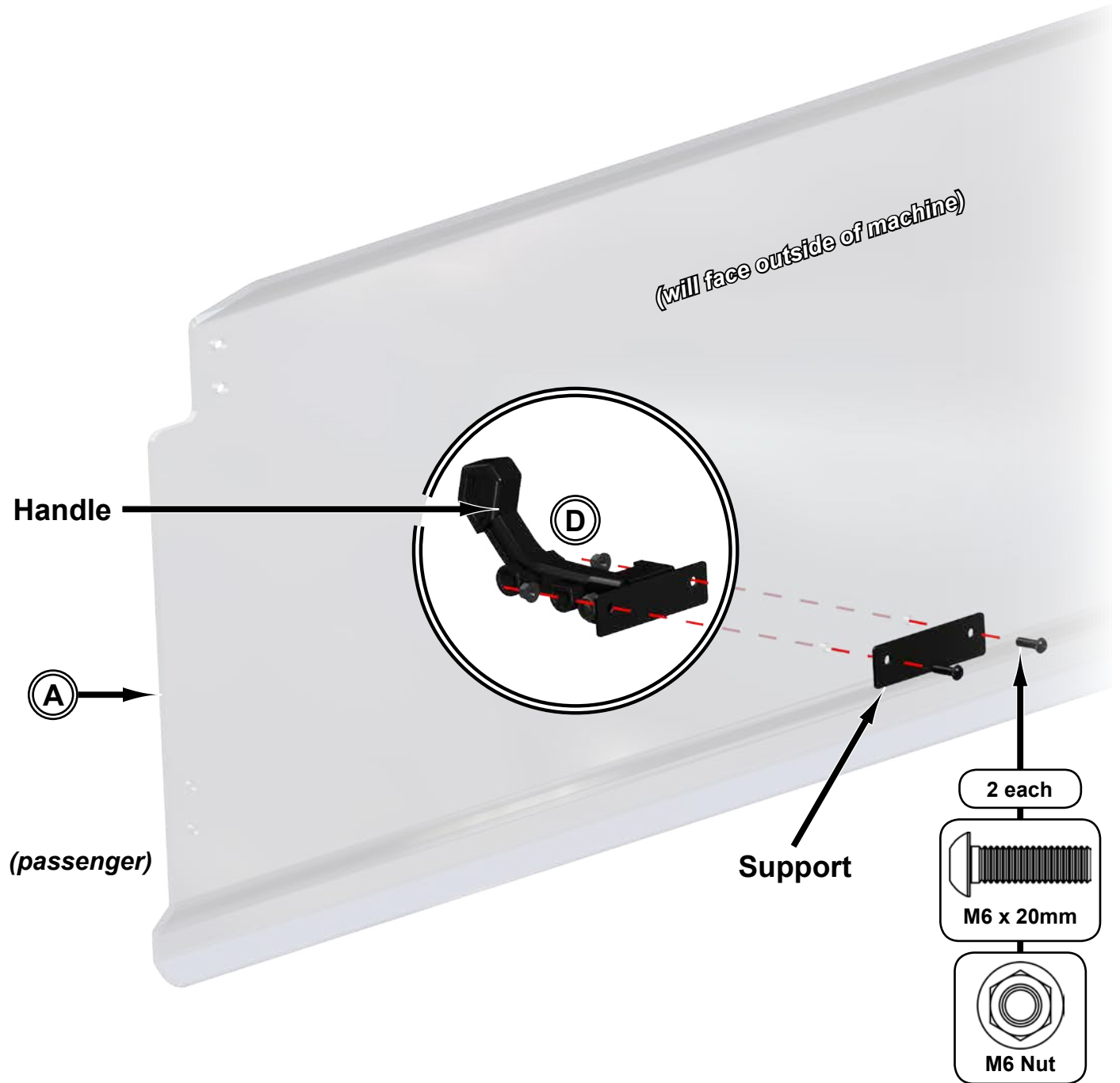

- Install Pivot Blocks (E) to Upper Windshield (A) with hardware shown.
- Install Clamp (F) and Support (K) to Pivot Block (E) with hardware shown.
- Repeat for opposite side.

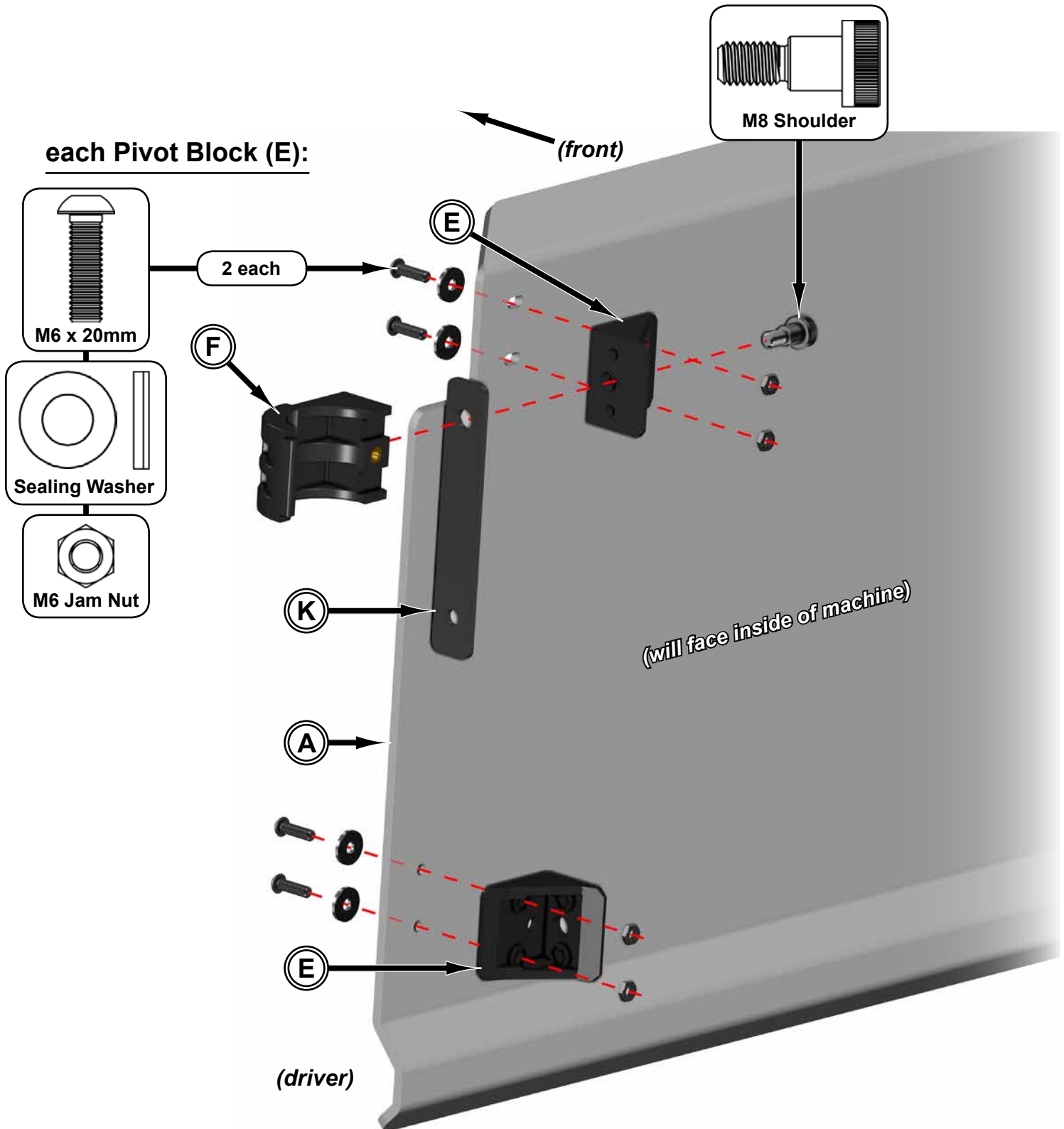

- Install Clamp (F) and Gas Strut (C) to Support (K).
- Secure Gas Strut (C) to Pivot Block (E) with M8 Nylock Nut.
- Repeat for opposite side.

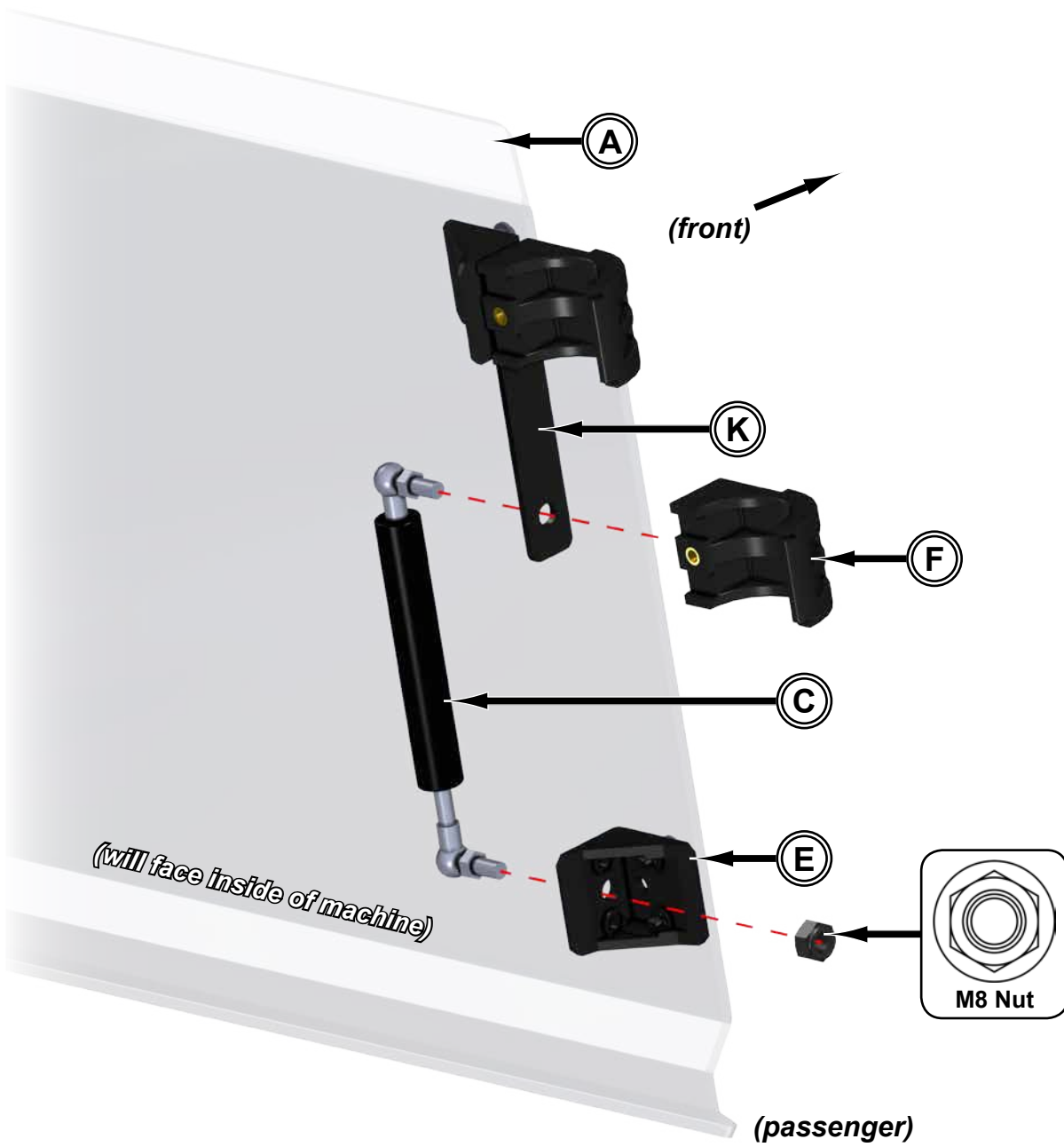

- Install Upper Windshield (A) to Roll Cage with bolts included with Clamps (F).

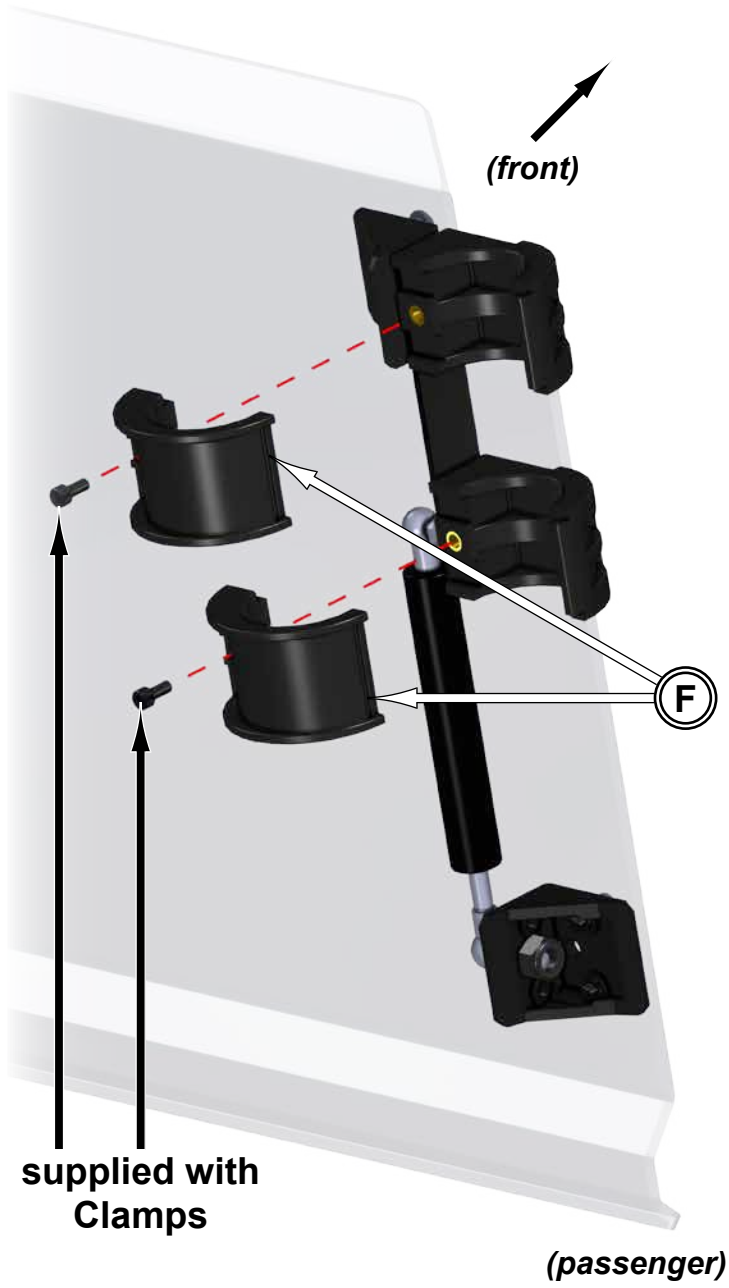

- Engage Latch and align Windshield assembly to machine making sure that Seal, on Lower Windshield (B), is in contact with Hood.
- Tighten hardware completely.

